

INTRODUCTION



A new highly economical face milling family has been launched. The latest Pramet range includes three variants of a 16-edged ONMX insert for depths of cut up to 4 mm. This includes a specific wiper insert ONMX-W for high quality surface finish in high feeds, and two variants of 8-edged roughing insert SNMX for depths of cut up to 7 mm. Several geometries and cutters are available for machining a wide range of materials.



ONMX-F

- Economical 16-edged pressed insert
- Steels, stainless steels and HRSA
- Light cuts



ONMX-M

- Economical 16-edged pressed insert
- Steels, hard steels, stainless steels, HRSA
- Medium cuts



ONMX-R

- Economical 16-edged pressed insert
- Steels, cast irons, hard steels
- Rough cuts



MILLING CUTTERS AND INSERTS

INSERTS FEATURES & BENEFITS

Octagonal, directly pressed negative inserts.

▶ **16 CUTTING EDGES**
for even greater economy and cost saving.

Geometries F, M and R on inserts ONMX.

▶ **EASY TO SELECT**
a geometry for light, medium or rough cuts.

Optimized combination of grades and geometries.

▶ **VERSATILE USE**
in wide range of workpiece materials.

Square, directly pressed negative inserts.

▶ **8 CUTTING EDGES**
insert SNMX for depth of cut up to 7 mm.

High depth of cut capability on SNMX inserts.

▶ **HIGH METAL REMOVAL RATE**
in economical solution.

Additional wiper insert ONMX-W available.

▶ **HIGH SURFACE QUALITY**
in larger diameter cutters and higher feeds.

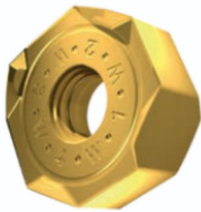
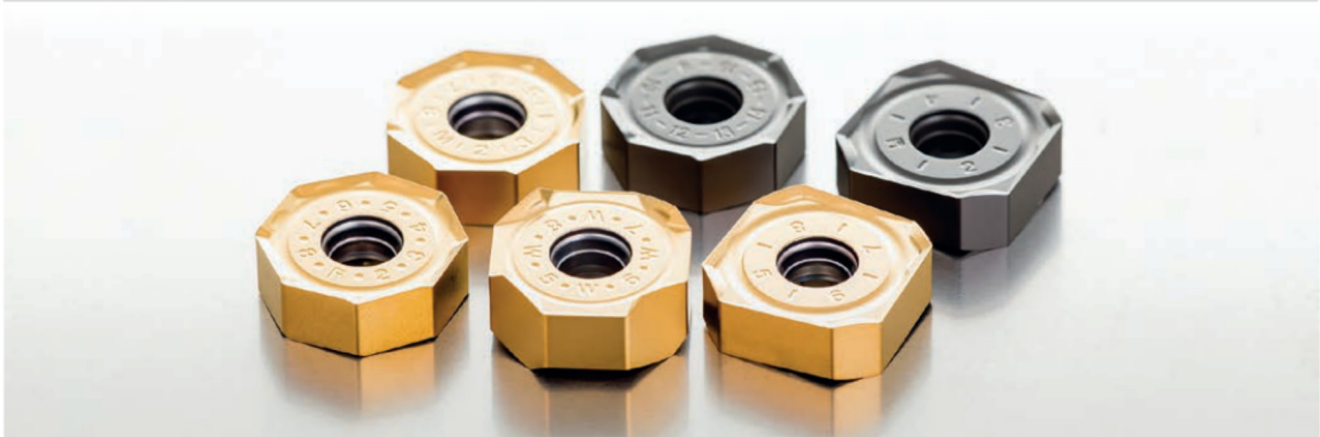

ONMX-W

- Wiper insert
- Steels, stainless steels
- High quality surface finish

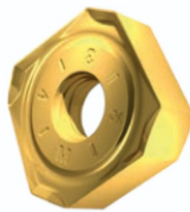

SNMX-M

- Economical 8-edged roughing insert
- Steels, hard steels, stainless steels, HRSA
- Medium cuts

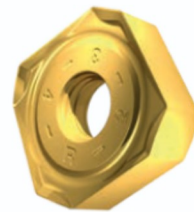

SNMX-R

- Economical 8-edged roughing insert
- Steels, cast irons, hard steels
- Rough cuts



SON06C

ECONOMICAL 16-EDGED FACE MILLING

CUTTERS SON06C – FEATURES & BENEFITS

Cutter body made of high quality, nickelized tool steel.

▶ **HIGH DURABILITY**
of hardened cutter body.

Strong clamping screw and easily accessible hardened insert seat.

▶ **SIMPLE AND SAFE**
clamping of insert.

Internal coolant on entire assortment, including large-sized diameters.

▶ **IMPROVED TOOL LIFE**
and better chip evacuation, providing high surface quality and reliability.

Shell type cutters available in wide diameter range and various tooth pitches.

▶ **VARIOUS OPTIONS**
for a broad range of applications.



SON06C

- Shell body
- DC range
50 – 250 mm
2.00 – 6.00 inch



MILLING CUTTERS AND INSERTS

FACE MILLING EXAMPLES

Workpiece: Carbon steel plate (210 HB)
 Material: 1.1191 / C45
 Cutter: 63A06R-S45ON06-C
 Coolant: Compressed air

Cutting conditions			
v_c (m/min)	f_z (mm)	a_p (mm)	a_e (mm)
250	0.25	2	50
Insert geometry test			Tool life (min)
ONMX 060508SR- M :M8330			42

ONMX 060508SR-**M**:M8330, 42 min

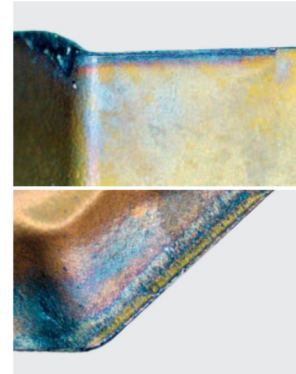

WMG P2.2

Workpiece: Stainless steel plate (145 HB)
 Material: 1.4404 / 316L
 Cutter: 63A06R-S45ON06-C
 Coolant: Compressed air

Cutting conditions			
v_c (m/min)	f_z (mm)	a_p (mm)	a_e (mm)
160	0.15	2	50
Insert geometry test			Tool life (min)
ONMX 060508SR- F :M6330			58

ONMX 060508SR-**F**:M6330, 58 min

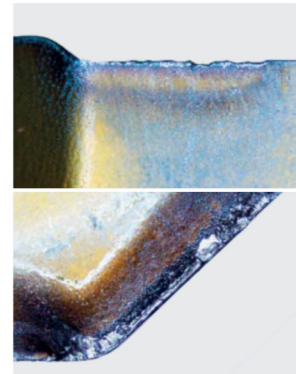

WMG M3.1

Workpiece: Stainless steel plate (145 HB)
 Material: 1.4404 / 316L
 Cutter: 63A06R-S45ON06-C
 Coolant: Soluble oil emulsion (~ 10%)

Cutting conditions			
v_c (m/min)	f_z (mm)	a_p (mm)	a_e (mm)
80	0.15	2	50
Insert geometry test			Tool life (min)
ONMX 060508SR- F :M6330			56

ONMX 060508SR-**F**:M6330, 56 min

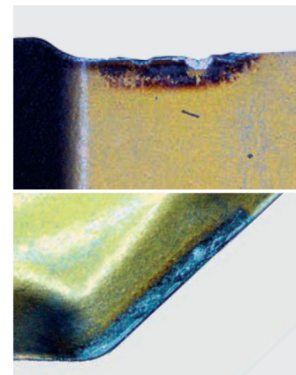

WMG M3.1

Workpiece: Cast iron plate (205 HB)
 Material: GG25 / FC250
 Cutter: 63A06R-S45ON06-C
 Coolant: Compressed air

Cutting conditions			
v_c (m/min)	f_z (mm)	a_p (mm)	a_e (mm)
250	0.4	2	50
Insert geometry test			Tool life (min)
ONMX 060508SR- R :M5315			137+

ONMX 060508SR-**R**:M5315, 137 min

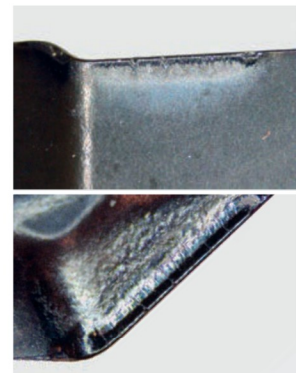

WMG K1.2



SON06C



PRAMET



ECON ON06 43° Face Mill with Double Negative Design and Internal Coolant

Highly economical and productive face mill utilising two types of double-sided negative inserts. Economical octagonal ON..06 inserts with 16 cutting edges and APMX of 4 mm, and productive square SN.. 17 inserts with 8 cutting edges and APMX of 7 mm. Arbor style available with differential tooth pitch. Body treated for longer tool life.

KAPR	43°
APMX	4.0 (7.0)

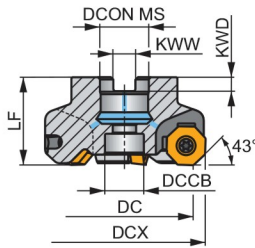
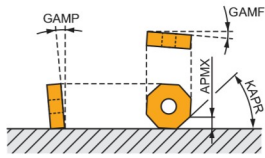

DC 50 – 125 mm

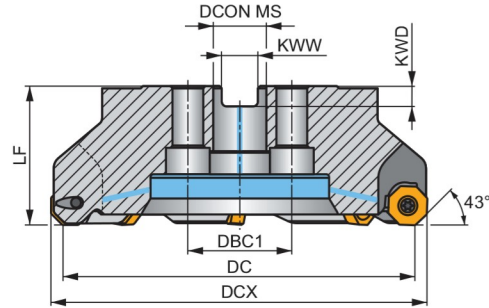

DC 160 – 250 mm

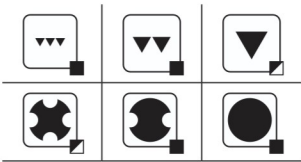

0.04 - 0.25



Product	DC	DCX	DCON MS	DCCB	DBC1	LF	KWW	KWD	GAMF	GAMP								
	(mm)	(mm)	(mm)	(mm)	(mm)	(mm)	(mm)	(mm)	(°)	(°)								
50A04R-S450N06-C	50	60.8	22	16.5	-	40	10.4	6.3	-10	-5	4	✓	9400	✓	0.42	GI342	C0621	-
50A05R-S450N06-C	50	60.8	22	16.5	-	40	10.4	6.3	-10	-5	5	-	9400	✓	0.39	GI342	C0621	-
63A05R-S450N06-C	63	73.8	22	18.1	-	40	10.4	6.3	-10	-5	5	✓	8400	✓	0.59	GI342	C0621	-
63A06R-S450N06-C	63	73.8	22	18.1	-	40	10.4	6.3	-10	-5	6	✓	8400	✓	0.55	GI342	C0621	-
80A06R-S450N06-C	80	90.8	27	22.1	-	50	12.4	7	-10	-5	6	✓	7500	✓	1.27	GI342	C0622	-
80A08R-S450N06-C	80	90.8	27	22.1	-	50	12.4	7	-10	-5	8	-	7500	✓	1.19	GI342	C0622	-
100A08R-S450N06-C	100	110.8	32	30.1	-	50	14.4	8	-10	-5	8	✓	6700	✓	1.88	GI342	C0620	AC002
100A10R-S450N06-C	100	110.8	32	30.1	-	50	14.4	8	-10	-5	10	-	6700	✓	1.81	GI342	C0620	AC002
125A08R-S450N06-C	125	135.8	40	56.1	-	63	16.4	9	-10	-5	8	✓	6000	✓	3.53	GI342	C0620	AC003
125A10R-S450N06-C	125	135.8	40	56.1	-	63	16.4	9	-10	-5	10	✓	6000	✓	3.65	GI342	C0620	AC003
125A12R-S450N06-C	125	135.8	40	56.1	-	63	16.4	9	-11	-5	12	-	6000	✓	3.55	GI342	C0620	AC003
160C08R-S450N06-C	160	170.8	40	-	66.7	63	16.4	9.25	-10	-5	8	✓	5700	✓	5.54	GI342	C0623	-
160C12R-S450N06-C	160	170.8	40	-	66.7	63	16.4	9.25	-10	-5	12	✓	5700	✓	5.74	GI342	C0623	-
160C14R-S450N06-C	160	170.8	40	-	66.7	63	16.4	9.25	-11	-5	14	-	5700	✓	5.65	GI342	C0623	-
200C12R-S450N06-C	200	210.8	60	-	101.6	63	25.8	14.25	-10	-5	12	✓	4700	✓	9.00	GI342	C0624	-
200C16R-S450N06-C	200	210.8	60	-	101.6	63	25.8	14.25	-10	-5	16	-	4700	✓	9.02	GI342	C0624	-
250C14R-S450N06-C	250	260.8	60	-	101.6	63	25.8	14.25	-10	-5	14	✓	4300	✓	15.46	GI342	C0625	-
250C18R-S450N06-C	250	260.8	60	-	101.6	63	25.8	14.25	-10	-5	18	-	4300	✓	15.51	GI342	C0625	-

GI342	ONMX 0605..	ONMX 0605..-W..	SNMX 1705..



C0620	US 45013A-T20P	5.0	M 5	13	SDR T20P-T	-	-	-	-
C0621	US 45013A-T20P	5.0	M 5	13	SDR T20P-T	HS 1030C	-	-	-
C0622	US 45013A-T20P	5.0	M 5	13	SDR T20P-T	HS 1230C	-	-	-
C0623	US 45013A-T20P	5.0	M 5	13	SDR T20P-T	HS 1240C	CAC 160C	HSD 0825C	HXK 5
C0624	US 45013A-T20P	5.0	M 5	13	SDR T20P-T	HS 1655C	CAC 200C	HSD 1025C	HXK 7
C0625	US 45013A-T20P	5.0	M 5	13	SDR T20P-T	HS 1655C	CAC 250C	HSD 1025C	HXK 7

AC002	KS 1635	K.FMH32
AC003	KS 2040	K.FMH40

ONMX 06



	IC	D1	S
	(mm)	(mm)	(mm)
0605	17.000	5.70	7.08

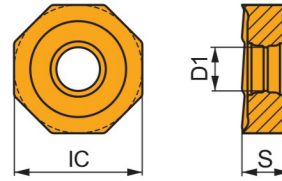

Suitability and starting values for cutting speed (vc), feed (f) and depth of cut (ap). Refer to our Machining Calculator app for further calculations.

Product	RE (mm)	P			M			K			N			S			H		
		vc (m/min)	f (mm/tooth)	ap (mm)	vc (m/min)	f (mm/tooth)	ap (mm)	vc (m/min)	f (mm/tooth)	ap (mm)	vc (m/min)	f (mm/tooth)	ap (mm)	vc (m/min)	f (mm/tooth)	ap (mm)			

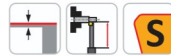
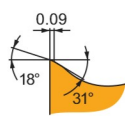
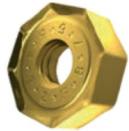

F geometry is sharp and used for finishing, suitable for large overhang or thin walled and slim workpiece applications. Designed with highly positive rake, narrow T-land and rounding of cutting edge for light machining.

ONMX 060508SR-F	8215	0.8	■ 275	0.10	2.0	■ 165	0.09	2.0	■ -	-	-	■ -	-	-	■ 65	0.07	1.6	■ -	-	-
	M6330	0.8	■ 230	0.10	2.0	■ 165	0.09	2.0	■ -	-	-	■ -	-	-	■ 65	0.07	1.6	■ -	-	-
	M8330	0.8	■ 270	0.10	2.0	■ 160	0.09	2.0	■ -	-	-	■ -	-	-	■ 65	0.07	1.6	■ -	-	-
	M8340	0.8	■ 245	0.10	2.0	■ 145	0.09	2.0	■ -	-	-	■ -	-	-	■ 60	0.07	1.6	■ -	-	-
	M9340	0.8	■ 320	0.10	2.0	■ 190	0.09	2.0	■ -	-	-	■ -	-	-	■ 80	0.07	1.6	■ -	-	-

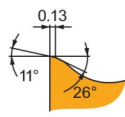

M geometry is versatile and the first choice for a wide range of working conditions. Designed with positive rake, medium T-land and rounding of cutting edge for medium machining.

ONMX 060508SR-M	8215	0.8	■ 230	0.20	2.0	■ 135	0.18	2.0	■ -	-	-	■ -	-	-	■ 55	0.14	1.6	■ 45	0.14	1.0
	M6330	0.8	■ 195	0.20	2.0	■ 140	0.18	2.0	■ -	-	-	■ -	-	-	■ 55	0.14	1.6	■ -	-	-
	M8330	0.8	■ 230	0.20	2.0	■ 135	0.18	2.0	■ -	-	-	■ -	-	-	■ 55	0.14	1.6	■ 45	0.14	1.0
	M8340	0.8	■ 210	0.20	2.0	■ 125	0.18	2.0	■ -	-	-	■ -	-	-	■ 50	0.14	1.6	■ -	-	-
	M9325	0.8	■ 285	0.20	2.0	■ -	-	-	■ -	-	-	■ -	-	-	■ -	-	-	■ 55	0.14	1.0
M9340	0.8	■ 255	0.20	2.0	■ 150	0.18	2.0	■ -	-	-	■ -	-	-	■ 60	0.14	1.6	■ -	-	-	



Suitability and starting values for cutting speed (vc), feed (f) and depth of cut (ap). Refer to our Machining Calculator app for further calculations.

Product	RE (mm)	P			M			K			N			S			H		
		vc (m/min)	f (mm/tooth)	ap (mm)	vc (m/min)	f (mm/tooth)	ap (mm)	vc (m/min)	f (mm/tooth)	ap (mm)	vc (m/min)	f (mm/tooth)	ap (mm)	vc (m/min)	f (mm/tooth)	ap (mm)	vc (m/min)	f (mm/tooth)	ap (mm)

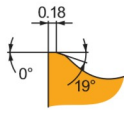

R geometry is strong and used for roughing and heavy working conditions. Designed with slightly positive rake, wide T-land and rounding of cutting edge for rough machining.

ONMX 060508SR-R	8215	0.8	210	0.30	2.0	–	–	–	195	0.30	2.0	–	–	–	–	–	–	40	0.21	1.0
	M5315	0.8	255	0.30	2.0	–	–	–	240	0.30	2.0	–	–	–	–	–	–	50	0.21	1.0
	M8330	0.8	210	0.30	2.0	–	–	–	195	0.30	2.0	–	–	–	–	–	–	40	0.21	1.0
	M8340	0.8	190	0.30	2.0	–	–	–	180	0.30	2.0	–	–	–	–	–	–	–	–	–
	M9325	0.8	250	0.30	2.0	–	–	–	235	0.30	2.0	–	–	–	–	–	–	50	0.21	1.0

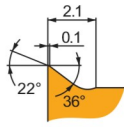

Wiper design for improved surface finish when machining with large cutters and high feed rate.

ONMX 060508SR-W	8215	0.8	340	0.10	0.3	200	0.09	0.3	–	–	–	–	–	–	–	–	–	–	–	–
	M8330	0.8	325	0.10	0.3	195	0.09	0.3	–	–	–	–	–	–	–	–	–	–	–	–

SNMX 17



	IC (mm)	D1 (mm)	S (mm)
1705	17.000	5.70	5.56

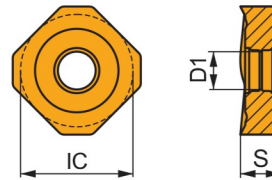

Suitability and starting values for cutting speed (vc), feed (f) and depth of cut (ap). Refer to our Machining Calculator app for further calculations.

Product	RE (mm)	P			M			K			N			S			H		
		vc (m/min)	f (mm/tooth)	ap (mm)	vc (m/min)	f (mm/tooth)	ap (mm)	vc (m/min)	f (mm/tooth)	ap (mm)	vc (m/min)	f (mm/tooth)	ap (mm)	vc (m/min)	f (mm/tooth)	ap (mm)	vc (m/min)	f (mm/tooth)	ap (mm)

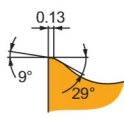
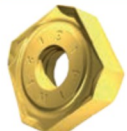

M geometry is versatile and the first choice for a wide range of working conditions. Designed with positive rake, medium T-land and rounding of cutting edge for medium machining.

SNMX 170508SR-M	8215	0.8	265	0.20	4.0	155	0.18	4.0	–	–	–	–	–	–	65	0.14	3.2	50	0.14	1.0
	M6330	0.8	225	0.20	4.0	160	0.18	4.0	–	–	–	–	–	–	65	0.14	3.2	–	–	–
	M8330	0.8	265	0.20	4.0	155	0.18	4.0	–	–	–	–	–	–	65	0.14	3.2	50	0.14	1.0
	M8340	0.8	240	0.20	4.0	140	0.18	4.0	–	–	–	–	–	–	60	0.14	3.2	–	–	–
	M9325	0.8	325	0.20	4.0	–	–	–	–	–	–	–	–	–	–	–	–	65	0.14	1.0
	M9340	0.8	295	0.20	4.0	175	0.18	4.0	–	–	–	–	–	–	70	0.14	3.2	–	–	–

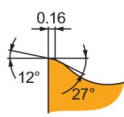
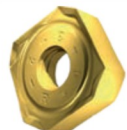

R geometry is strong and used for roughing and heavy working conditions. Designed with slightly positive rake, wide T-land and rounding of cutting edge for rough machining.

SNMX 170508SR-R	8215	0.8	240	0.30	4.0	–	–	–	225	0.30	4.0	–	–	–	–	–	–	45	0.21	1.0
	M5315	0.8	300	0.30	4.0	–	–	–	285	0.30	4.0	–	–	–	–	–	–	60	0.21	1.0
	M8330	0.8	240	0.30	4.0	–	–	–	225	0.30	4.0	–	–	–	–	–	–	45	0.21	1.0
	M8340	0.8	220	0.30	4.0	–	–	–	205	0.30	4.0	–	–	–	–	–	–	–	–	–
	M9325	0.8	290	0.30	4.0	–	–	–	275	0.30	4.0	–	–	–	–	–	–	55	0.21	1.0



a_e / DC	5 %	10 %	15 %	20 %	25 %	30 %	40 %	50 %	60 %	70 %	75 %	80 %	90 %	100 %
	1.48	1.35	1.27	1.22	1.19	1.16	1.11	1.08	1.05	1.03	1.00	1.00	1.00	1.00
	2.20	1.60	1.35	1.20	1.10	0.95	0.85	0.75	0.85	0.95	1.00	1.00	1.00	1.00
	0.64	0.64	0.64	0.64	0.64	0.65	0.65	0.67	0.68	0.71	0.72	0.74	0.79	1.00

	ONMX 06-F	ONMX 06-M	ONMX 06-R	ONMX 06-W	SNMX 17-M	SNMX 17-R
	0.80	0.80	0.80	0.80	0.80	0.80
	0.75	0.75	0.75	4.30	0.70	0.70

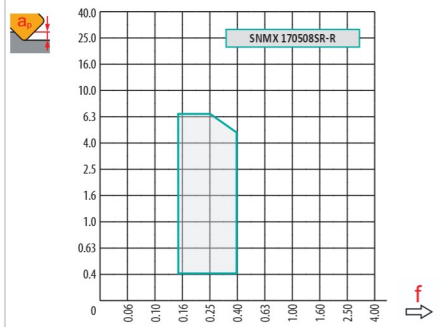
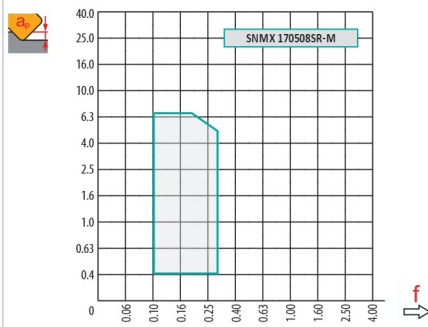
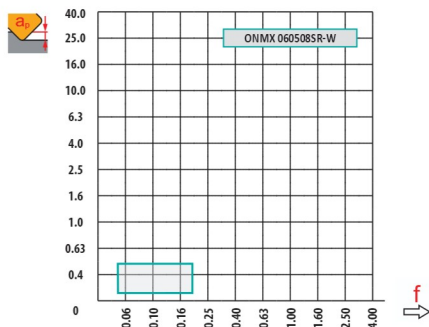
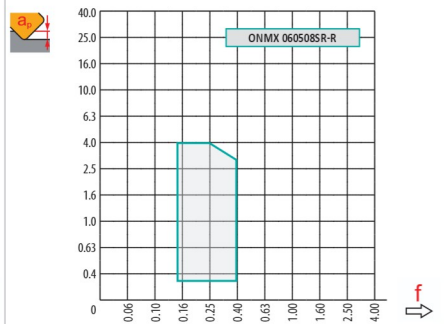
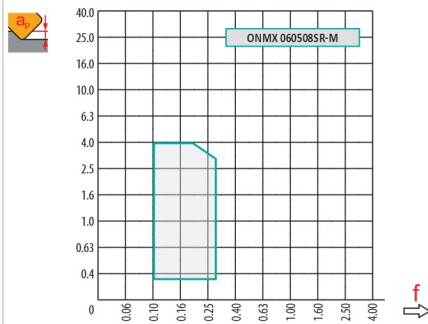
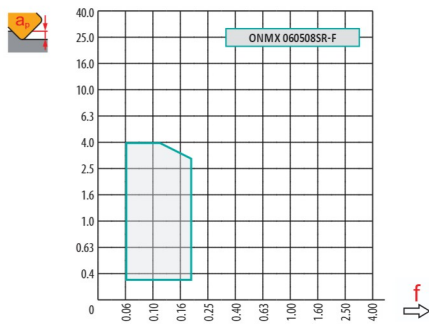

		0.50	1.00	1.50	2.00	2.50	3.00	3.50	4.00
50		51.06	52.11	53.19	54.27	55.35	56.43	57.51	58.59
63		64.06	65.11	66.19	67.27	68.35	69.43	70.51	71.59
80		81.06	82.11	83.19	84.27	85.35	86.43	87.51	88.59
100		101.06	102.11	103.19	104.27	105.35	106.43	107.51	108.59
125		126.06	127.11	128.19	129.27	130.35	131.43	132.51	133.59
160		161.06	162.11	163.19	164.27	165.35	166.43	167.51	168.59
200		201.06	202.11	203.19	204.27	205.35	206.43	207.51	208.59
250		251.06	252.11	253.19	254.27	255.35	256.43	257.51	258.59



DC		S							
		0.00	1.00	2.00	3.00	4.00	5.00	6.00	7.00
50		47.24	49.40	51.56	53.73	55.90	58.06	60.23	62.40
63		60.24	62.40	64.56	66.73	68.90	71.06	73.23	75.40
80		77.24	79.40	81.56	83.73	85.90	88.06	90.23	92.40
100		97.24	99.40	101.56	103.73	105.90	108.06	110.23	112.40
125		122.24	124.40	126.56	128.73	130.90	133.06	135.23	137.40
160		157.24	159.40	161.56	163.73	165.90	168.06	170.23	172.40
200		197.24	199.40	201.56	203.73	205.90	208.06	210.23	212.40
250		247.24	249.40	251.56	253.73	255.90	258.06	260.23	262.40

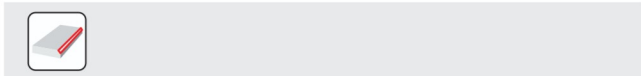

DC	X.V	f _{max}
50	1.35	0.36
63	1.39	0.40
80	1.44	0.45
100	1.48	0.51
125	1.53	0.57
160	1.58	0.64
200	1.63	0.72
250	1.68	0.80

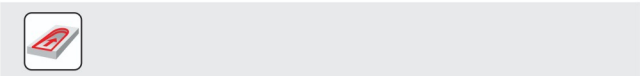

DC	O	
	RPMX	APMX/I
50	0.3	0.4/100
63	0.2	0.25/100
80	0.2	0.2/100
100	0.1	0.1/100
125	0.1	0.05/100

DC	S	
	RPMX	APMX/I
47.24	0.1	0.1/100
60.24	0.1	0.05/100
77.24	0.1	0.05/100

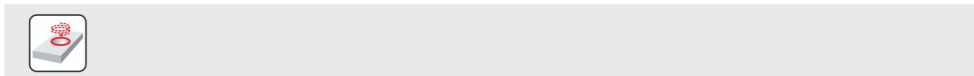

DC	O			
	DMIN	DMAX	S MAX DMIN	S MAX DMAX
50	98	110	0.55	0.95
63	123	136	0.55	0.85
80	157	170	0.65	0.85
100	197	210	0.65	0.8
125	247	260	0.65	0.8
160	317	330	0.6	0.7
200	397	410	0.7	0.8
250	497	510	0.6	0.7

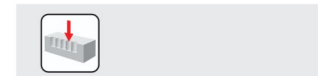

O
11.5

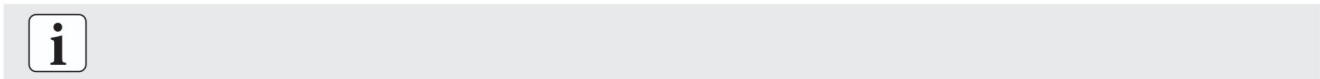

	<table border="1"> <tr> <td>-> 4.0</td> <td>16</td> </tr> <tr> <td>-> 5.1</td> <td>14</td> </tr> <tr> <td>-> 10.7</td> <td>8</td> </tr> <tr> <td>-> 11.5</td> <td>6</td> </tr> </table>	-> 4.0	16	-> 5.1	14	-> 10.7	8	-> 11.5	6		<table border="1"> <tr> <td>-> 7.0</td> <td>8</td> </tr> <tr> <td>-> 11.4</td> <td>4</td> </tr> </table>	-> 7.0	8	-> 11.4	4
-> 4.0	16														
-> 5.1	14														
-> 10.7	8														
-> 11.5	6														
-> 7.0	8														
-> 11.4	4														

	<p>ONMX 06-W</p> <table border="1"> <tr> <td>-> 0.5</td> <td>8</td> </tr> </table>	-> 0.5	8
-> 0.5	8		